

LIFT² WORK



OPTS
OFFSHORE ACCESS SYSTEM

The OPTS by LIFT2WORK

The **OFFSHORE PASSENGER TRANSFER SYSTEM** or **OPTS** is a safe motion compensated transfer system for persons and load, that can transfer a max. of 6 persons from one moving position to another fixed position. A smooth, seamless, safe and accurate motion is guaranteed.

The OPTS is a NEW way to transfer people and/or tools and equipment in FULL COMPENSATED MODE. The OPTS is the first product configuration of its kind to be suitable for offshore applications.

This safe, simple and self-controlled supporting system for moving people from one offshore structure to another is a good alternative with a more attractive pricing for sale and rent as the W2W, bridges and gangways solutions. **Embrace the future by using the OPTS.** The OPTS is fully hydraulically compensated and controlled by the operator as it would be on a land based installation.

The OPTS is an excellent tool to access wind turbine platforms, oil and gas platforms and other sea going vessels or structures. The OPTS has the ability to move freely 360° with a reach of 24m horizontally, and more than 20m vertically above the ground/deck. It can also drop to 6m below the level of the deck/quay (for example) for rescue purposes etc. see operational window for more details.

The system of **LIFT2WORK B.V.** is a fully Dutch designed and built product. It has been designed specially to be used on any barge or vessel in the offshore and marine world. With an arm length of 10m and a basic footprint of 8'x40' (2440x12200) the OPTS can easily be integrated onto a deck construction. A smaller footprint of 8x12 (2440x3600) is available for permanent mounting. The available deck mounting frames provide a fast and smooth mounting possibility, and due to their light but strong and rigid construction, enables quick, easy and safe lifting and transport options. The OPTS can even be used to lift goods and tools with or without heave and/or motion compensation.

LOWER YOUR DAILY COST AND INCREASE YOUR OPERATIONAL WINDOW

With the deck reinforcements and the foundation brackets in place the installation is very easy and can be done in one day.

Due to the low weight of the complete configuration of the OPTS the motions are fast and accurate with a low consumption of energy.

Safe in all situations. Final BACK HOME and start position is determined and fixed for start and landing. In case of any malfunction or use outside the limitations of the system the OPTS will return to the BACK HOME position.

All system motions and functions are monitored and logged with sensors and cameras to safeguard the complete operations. A multi-function tool for all light offshore operations. For sale or rent.



General Technical Specifications

Environment	Sea State 4 Wind speed Wave frequency Ambient temperature Storage temperature Humidity Estimated life time	Hs 2,5 7,7 m/s till 20 m/s 0,18 to 0,55 Hz -20°C ...45°C -20°C ...45°C to 95% 10 years
Safety	Education and training Controls Redundancy Back home emergency	Simulator and onsite (one day) Failsafe two hands operation Full By any male function
Class	W2W and lifting app	DNV-GL ST-358 / 378
Transfer	Max persons Basket/platform Height max Outreach Below deck Turret rotation	6 persons@18 m to 4 persons@24 m Multi-function with approach sensors 20 meter 24 meter 6 meter 2x200 degrees
Lifting unmanned	Cargo lift mean boom Cargo under basket	2500 kg @ 18 meter 1000 kg @ 24meter
Lifting manned (1)	Cargo lift mean boom Cargo under basket	1200 kg @ 18 meter 500 kg @ 24meter
Fire Fighting	8 Beaufort	20 m/s One man operation
Rescue		Open
FPSO	Passenger transfer	Pending on request
Hydraulic	Installed Power E supply	2 x 75 kW pressure pumps 400V/60Hz stabilized
Emergency	Back-up system	Accumulators
Controls	Human Machine Interface Double hands Full motion compensated	Fully with logging Dead man button DP 2 required
OPTS	Compensation	2.5 by 6 sec
Fully active Pending on location and RAO of vessel	Roll Pitch Yaw Surge Sway Accuracy of approach Speed	± 6° ± 6° ± 6° 1,0 1,0 10 cm 0,5 m/sec <60 sec one cycle>
Weight app	Weight gross	15 ton by mobile version 10 ton by fixed version
Dimensions	Transport mode Footprint deck	40" x 10" x 8" HQ container 8"x 12" (2440x3600)
Vessel	Requirements RAO info	DP 2 Feasibility plot required

Applications Options

- Passenger transfer in full compensation mode with an accuracy of 10 cm
- Load lifting till 2500kg in Roll and Pitch compensation mode
- Load lifting till 1000kg in Roll, Pitch and Heave compensation mode
- Rescue operation or launching operations
- Pilotage or firefighting operations with remote control

Technical Dimensions Operational Window

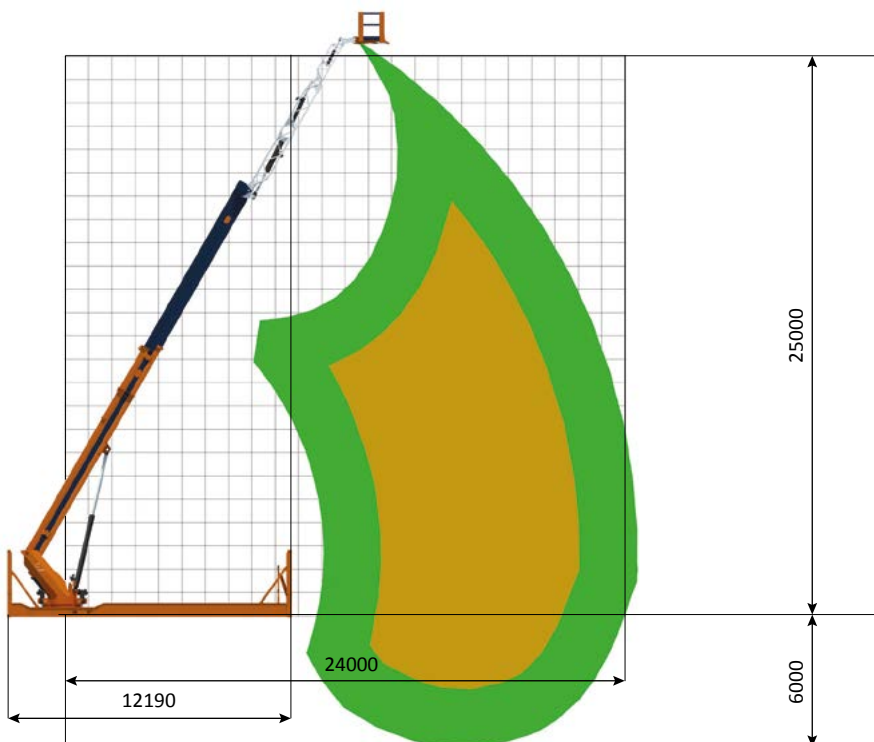
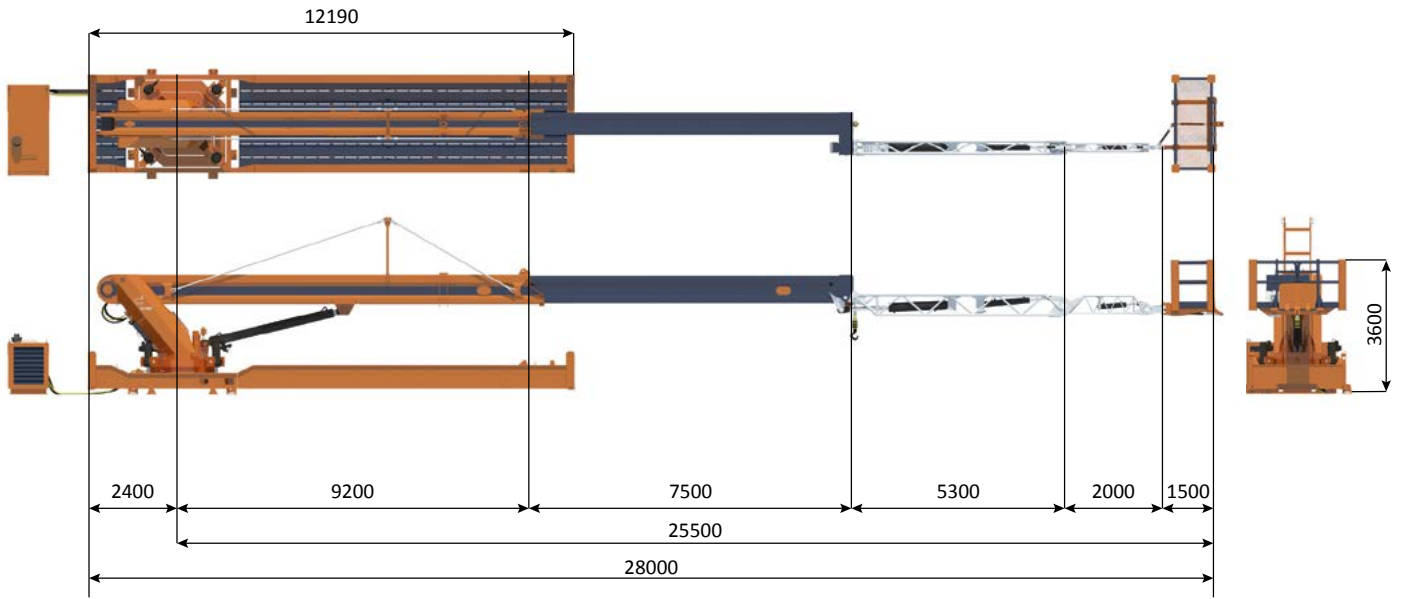

Motion Compensation

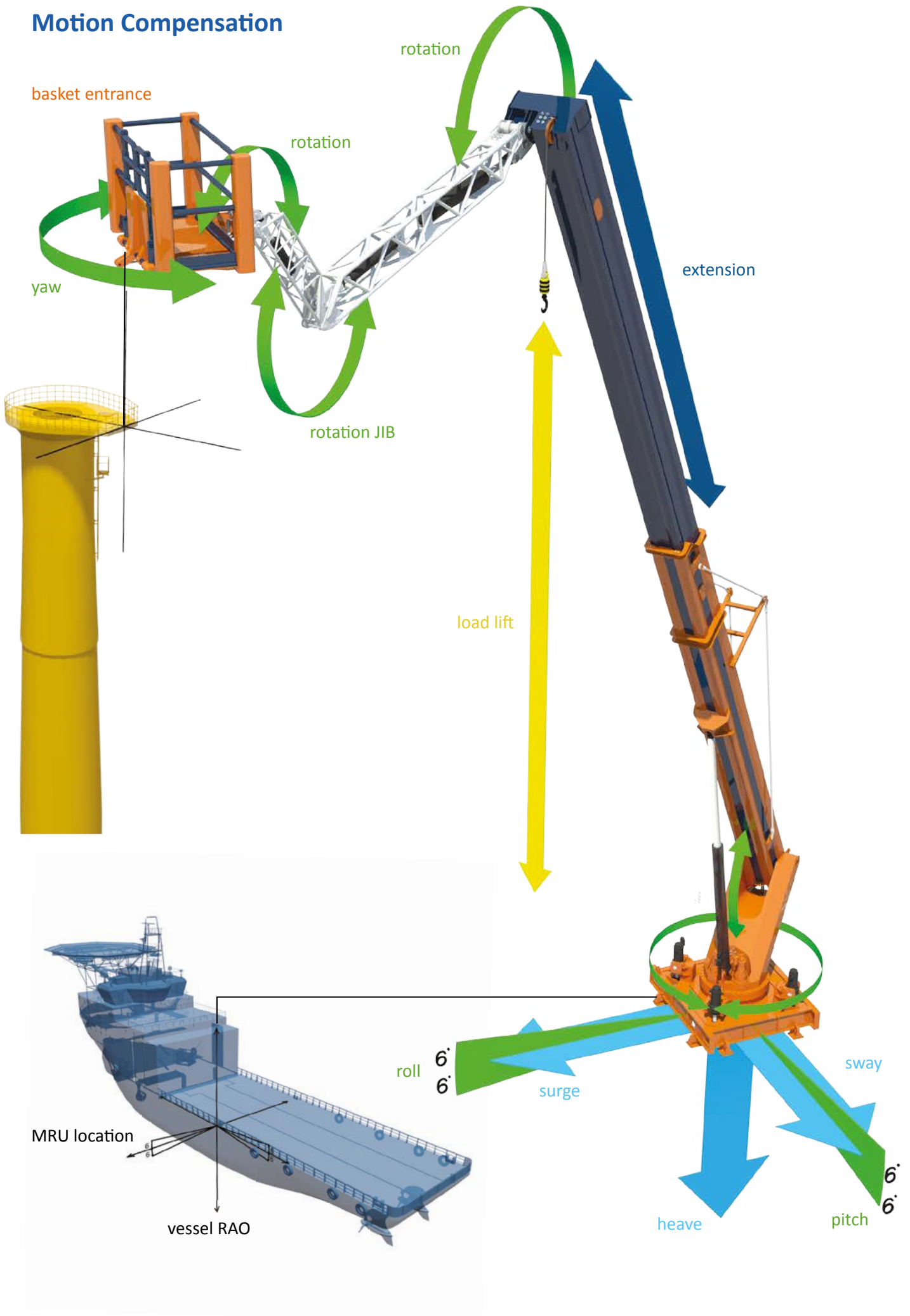



LIFT2WORK B.V.
Gieterijweg 17
3089 JZ Rotterdam
www.lift2work.nl
+31 (0) 88 26 28 688
info@lift2work.nl